

# BTI

## Light commercial atmospheric water heater

**BTI - 65/85/100**



Atmospheric water heater, primarily intended for light commercial/ industrial applications • Control, high limit and energy cut-off thermostats to ensure safe operation • Safety sensor to prevent flue spillage • Stainless-steel burner for natural or LP gas • Waterway access cover for comprehensive waterside tank maintenance • Replaceable magnesium anode • Fully automatic spark ignition to minimise standing losses • General fault indicator light • Optional ancillaries: Unvented kits • Destratification pump kit • Powered anode • Time clock kit • Flue fan kit • Time clock kit/7 day timer to minimise standing losses

# Technical specifications

		BTI 65	BTI 85	BTI 100
<b>Gas data natural gas 2H (G20)</b>				
Input*	kW	18.1	25.1	26.7
Output	kW	12.7	19.2	20.4
Inlet pressure	mbar	20	20	20
Gas consumption**	m <sup>3</sup> /h	1.7	2.4	2.5
Flue gas discharge temperature	°C	265	275	275
<b>Gas data butane 3+ (G30)</b>				
Input*	kW	17.2	24.5	26.0
Output	kW	12.3	19.2	20.4
Inlet pressure	mbar	30	30	30
Gas consumption**	kg/h	1.3	1.8	1.9
Flue gas discharge temperature	°C	265	275	275
<b>Gas data propane 3+ (G31)</b>				
Input*	kW	16.4	22.9	24.9
Output	kW	11.7	17.9	19.5
Inlet pressure	mbar	37	37	37
Gas consumption**	kg/h	1.2	1.6	1.8
Flue gas discharge temperature	°C	265	275	275
<b>General</b>				
Efficiency (gross)	%	70	77	77
Weight empty	kg	93	122	149
Maximum weight	kg	271	387	504
Storage capacity	l	178	265	355
Max. temperature setting	°C	80	80	80
Maximum working pressure	kPa (bar)		800 (8)	
<b>Draw-off capacity ***</b>				
Tcold = 10°C / Tset = Tmax				
30 min. ΔT=44°C	l	310	464	575
60 min. ΔT=44°C	l	433	652	774
90 min. ΔT=44°C	l	557	840	974
120 min. ΔT=44°C	l	681	1027	1173
Continuous ΔT=44°C	l/h	247	375	399
Heating-up time ΔT=44°C	min.	43	42	53
30 min. ΔT=50°C	l	272	408	506
60 min. ΔT=50°C	l	381	574	681
90 min. ΔT=50°C	l	490	739	857
120 min. ΔT=50°C	l	599	904	1032
Continuous ΔT=50°C	l/h	218	330	351
Heating-up time ΔT=50°C	min.	49	48	61
30 min. ΔT=55°C	l	248	371	460
60 min. ΔT=55°C	l	347	521	619
90 min. ΔT=55°C	l	446	672	779
120 min. ΔT=55°C	l	545	822	938
Continuous ΔT=55°C	l/h	198	300	319
Heating-up time ΔT=55°C	min.	54	53	67
<b>Electrical data</b>				
Power consumption	W	30	30	30
Power supply	VAC/Hz		230 (-15% +10% VAC)/50 (+/- 1Hz)	
<b>Shipping data</b>				
Weight incl. packaging	kg	105	140	167
Width packaging	mm	670	780	780
Height packaging	mm	1690	1640	1830
Depth packaging	mm	730	870	870

\* Gas data on gross value

\*\* Gas consumption at 15°C and 1013.25 mbar

\*\*\* Based on max. temperature setting and 10°C cold water

# Dimensions

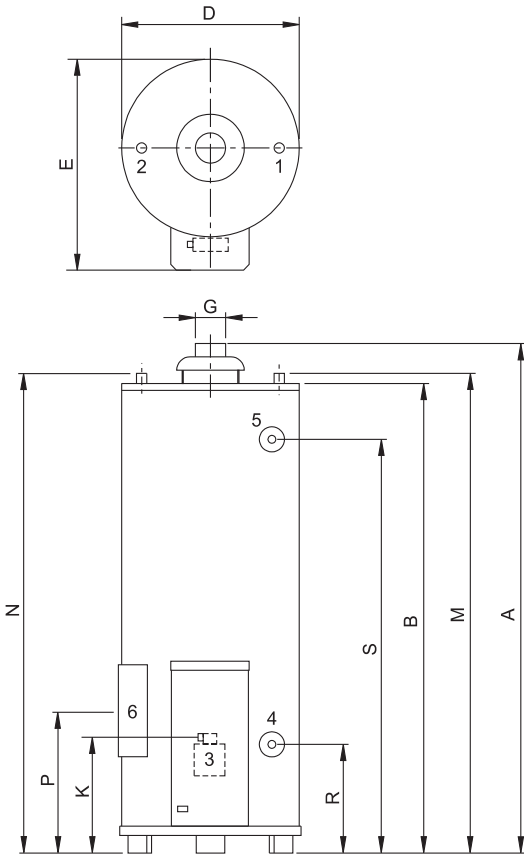

	BTI 65	BTI 85	BTI 100
A	1680	1585	1780
B	1510	1450	1640
D	520	645	675
E	655	770	775
G	100	130	130
K	340	340	340
M	1540	1505	1685
N	1540	1505	1685
R	295	285	285
S	1330	1280	1460
1 Cold water (external)	¾-14 NPT	1-11.5 NPT	1¼-11.5 NPT
2 Hot water (external)	¾-14 NPT	1-11.5 NPT	1¼-11.5 NPT
3 Gas control (internal)	Rp½	Rp½	Rp½
4 Tank drain valve (internal)	¾-14 NPT	¾-14 NPT	¾-14 NPT
5 T&P valve (internal)	¾-14 NPT	¾-14 NPT	¾-14 NPT
Dimensions in mm.			

# Ecodesign specifications

		BTI 65	BTI 85	BTI 100
<b>Energy labeling (G20)</b>				
Load Profil	-	XL	XXL	XXL
Energy labeling	-	B	B	B
Efficiency	%	62	61	60
Annual Electricity Consumption (AEC)	kWh	7	7	7
Daily Electricity Consumption	kWh	0.035	0.033	0.033
Annual Fuel Consumption (AEC)	GJ GCV	24	32	34
Daily Fuel Consumption	kWh GCV	34.168	40.294	40.651
Nitrogen Dioxide Emission (NO2)	mg/kWh GCV	185	161	193
Mixed Water of 40°C (according V40)	ltr.	378	496	723
Sound Power Level	dB	55	55	55

# Installation diagrams

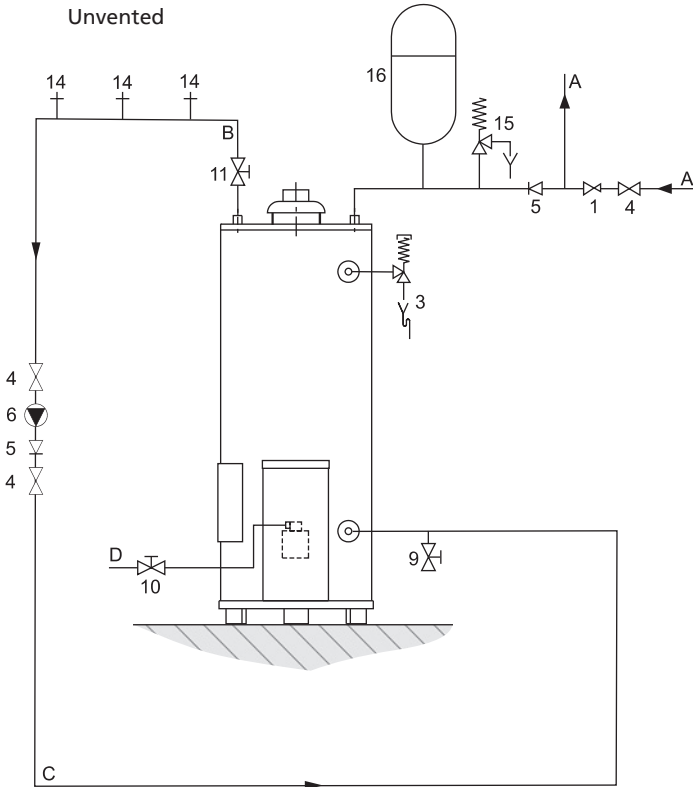

- 1 Pressure reducing valve
- 3 T&P valve
- 4 Stop valve
- 5 Non-return valve
- 6 Circulation pump
- 9 Drain valve
- 10 Gas valve
- 11 Service valve
- 14 Hot water tap
- 15 Expansion valve
- 16 Expansion vessel

- A Cold water supply  
 B Hot water outlet  
 C Circulation pipe  
 D Gas supply

A.O. Smith unvented system kits utilise combination valves.

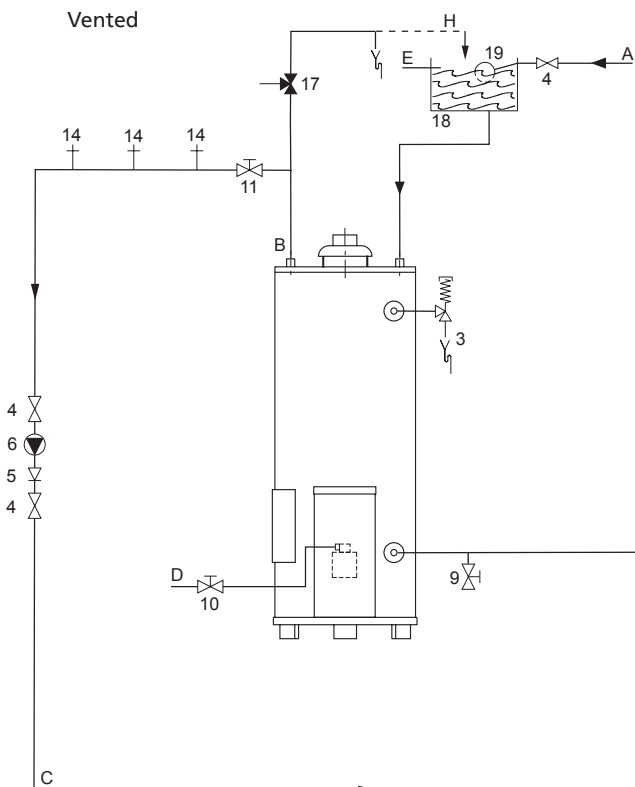

- 3 T&P valve
- 4 Stop valve
- 5 Non-return valve
- 6 Circulation pump
- 9 Drain valve
- 10 Gas valve
- 11 Service valve
- 14 Hot water tap
- 17 Three way valve
- 18 Water cistern
- 19 Float valve

- A Cold water supply  
 B Hot water outlet  
 C Circulation pipe  
 D Gas supply  
 E Overflow pipe  
 H Overflow protection

A BTI water heater should be installed in accordance with local standards and ventilation requirements (category B11BS).

In the instruction manual you will find all the necessary information regarding connection, installation and maintenance of the product; including information on the electrical connections.

Information regarding the recycling or disposal of the product can also be found in the manual. This manual is delivered with the appliance and can also be found on our website; [www.aosmith.co.uk](http://www.aosmith.co.uk).