

BFC Cyclone

Condensing Glass-Lined Water Heater

BFC - 28/30/50/60/80/100/120

- Fully room-sealed condensing high-efficiency water heater 97% (gross)
- Automatic gas/air premix burning system including burner modulation
- Delivered with low-maintenance inert anodes
- Efficiency 97% (gross)
- NO_x emission ≤ 30 ppm (dry – air free) – NO_x class 5
- Whisper quiet operation (<45 dB(A) at 2m distance from duct)
- Varying water temperature setting from 40°C to 80°C with use of week timer
- Flexible flue options (maximum length 100m) allow installations to be placed almost anywhere
- Easy fault diagnosis and computer controlled digital week timer
- Programmable for legionella purge cycle
- Voltage-free contact for general fault indication to BMS
- BFC Cyclone 80-120 are delivered on steel base for convenient transport and installation



Features and options

Fully room-sealed condensing high-efficiency water heater 97% (gross)
Automatic gas/air premix burning system including burner modulation
Delivered with low-maintenance inert anodes
Efficiency 97% (gross)
NOx emission ≤ 30 ppm (dry – air free) – NOx class 5
Whisper quiet operation (<45 dB(A) at 2m distance from duct)
Varying water temperature setting from 40°C to 80°C with use of week timer
Flexible flue options (maximum length 100m) allow installations to be placed almost anywhere
Easy fault diagnosis and computer controlled digital week timer
Programmable for legionella purge cycle
Voltage-free contact for general fault indication to BMS
BFC Cyclone 80-120 are delivered on steel base for convenient transport and installation

Energy labeling

		BFC 28	BFC 30	BFC 50	BFC 60	BFC 80	BFC 100	BFC 120
Load Profil	-	XXL	XXL	XXL	XXL	3XL	3XL	3XL
Energy labeling	-	A	A	A	A	-	-	-
Efficiency	%	91	91	91	90	93	93	92
Annual Electricity Consumption (AEC)	kWh	46	46	47	47	52	54	57
Daily Electricity Consumption	kWh	0.251	0.254	0.255	0.256	0.281	0.290	0.301
Annual Fuel Consumption (AEC)	GJ GCV	21	21	21	21	39	39	39
Daily Fuel Consumption	kWh GCV	26.501	26.552	26.562	26.632	49.811	49.922	50.060
Nitrogen Dioxide Emission (NO2)	mg/kWh GCV	24	32	36	37	34	36	37
Mixed Water of 40°C (according V40)	ltr.	1255	∞	∞	∞	1368	∞	∞
Sound Power Level	dB	46	47	55	59	54	59	62
Other Load Profil	-	-	-	3XL	3XL	-	-	-
Efficiency	%	-	-	89	89	-	-	-
Annual Electricity Consumption (AEC)	kWh	-	-	55	56	-	-	-
Daily Electricity Consumption	kWh	-	-	0.295	0.296	-	-	-
Annual Fuel Consumption (AEC)	GJ GCV	-	-	41	41	-	-	-
Daily Fuel Consumption	kWh GCV	-	-	52.051	52.162	-	-	-
Nitrogen Dioxide Emission (NO2)	mg/kWh GCV	-	-	36	37	-	-	-
Mixed Water of 40°C (according V40)	ltr.	-	-	559	601	-	-	-

Technical specifications

		BFC 28	BFC 30	BFC 50	BFC 60	BFC 80	BFC 100	BFC 120
Gas data natural gas 2H (G20)								
Input*	kW	32.2	33.3	52.2	63.3	86.6	105.5	128.8
Output	kW	31.0	32.7	50.3	60.4	84.2	100.7	121.8
Inlet pressure	mbar	20	20	20	20	20	20	20
Gas consumption **	m ³ /h	3.1	3.2	5.0	6.0	8.3	10.1	12.3
Flue gas discharge	°C	45	50	60	65	50	55	60
Gas data propane 3P (G31)								
Input*	kW	31.5	32.6	51.1	62.0	84.8	103.3	126.1
Output	kW	31.0	32.7	50.3	60.4	84.2	100.7	121.8
Inlet pressure	mbar	37/50	37/50	37/50	37/50	37/50	37/50	37/50
Gas consumption **	kg/h	2.3	2.3	3.7	4.4	6.1	7.4	9.0
Flue gas discharge	°C	45	50	60	65	50	55	60
General								
NO _x emission @0% O ₂	ppm	14	18	20	21	19	20	21
Noise level	dB(A)	< 45	< 45	< 45	< 45	< 45	< 45	< 45
Efficiency (gross)	%	96	98	96	95	97	95	95
Weight empty	kg	177	214	214	214	405	405	405
Maximum weight	kg	394	582	582	582	960	960	960
Storage capacity	l	217	368	368	368	480	480	480
Max. temperature setting	°C	80	80	80	80	80	80	80
Maximum working pressure	kPa (bar)	800 (8)						
Draw-off capacity ***								
T_{set} = 65°C / T_{cold} = 10°C								
30 min. ΔT 44°C	l	430	550	730	840	1100	1300	1500
60 min. ΔT 44°C	l	730	870	1300	1500	1900	2300	2600
90 min. ΔT 44°C	l	1100	1200	1800	2100	2800	3200	3800
120 min. ΔT 44°C	l	1400	1500	2300	2700	3600	4200	5000
Continuous ΔT 44°C	l/h	610	640	990	1200	1700	2000	2400
Heating-up time ΔT=44°C								
30 min. ΔT 50°C	l	360	450	620	720	910	1100	1300
60 min. ΔT 50°C	l	630	730	1100	1300	1700	2000	2300
90 min. ΔT 50°C	l	900	1100	1500	1800	2400	2800	3400
120 min. ΔT 50°C	l	1200	1300	2000	2300	3100	3700	4400
Continuous ΔT 50°C	l/h	540	570	870	1100	1500	1800	2100
Heating-up time ΔT 50°C								
30 min ΔT=55°C	l	320	390	540	630	800	920	1100
60 min ΔT=55°C	l	560	650	940	1100	1500	1700	2100
90 min ΔT=55°C	l	800	900	1400	1600	2200	2500	3000
120 min ΔT=55°C	l	1100	1200	1800	2100	2800	3300	4000
Continuous ΔT 55°C	l/h	490	520	790	950	1400	1600	2000
Heating-up time ΔT 55°C								
30 min	min.	27	43	28	23	22	18	15
Electrical data								
Power consumption	W	45	45	75	115	95	145	240
Power supply	VAC/Hz	230 (-15% +10% VAC)/50 (±1Hz)						
Shipping data								
Weight incl. packaging	kg	196	235	235	235	425	425	425
Width packaging	mm	790	790	790	790	920	920	920
Height packaging	mm	1550	2080	2080	2080	2060	2060	2060
Depth packaging	mm	950	950	950	950	1020	1020	1020

* Gas data on gross value

** Gas consumption at 15°C en 1013,25 mbar

*** Based on nat gas

Dimensions

BFC 28-60

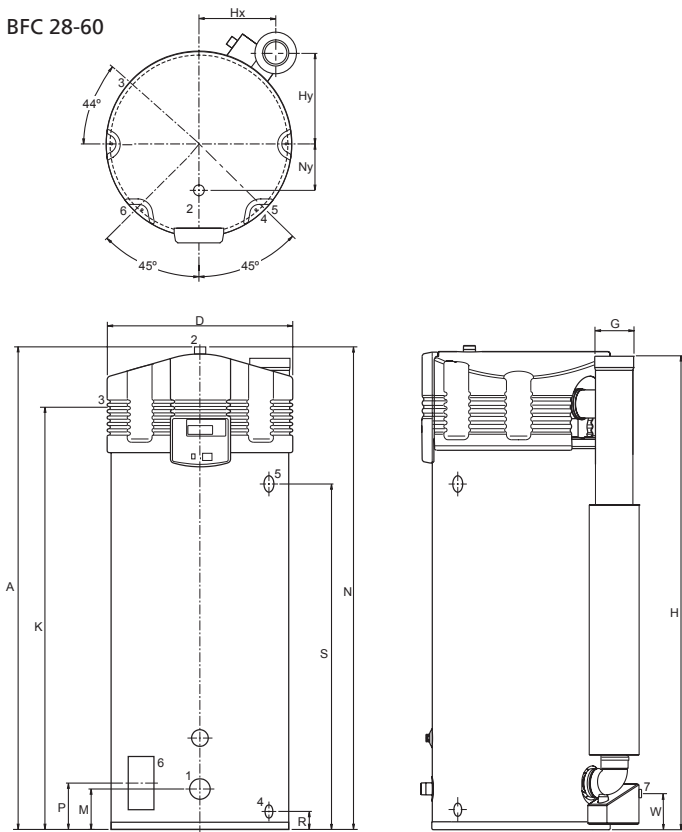

BFC 80-120

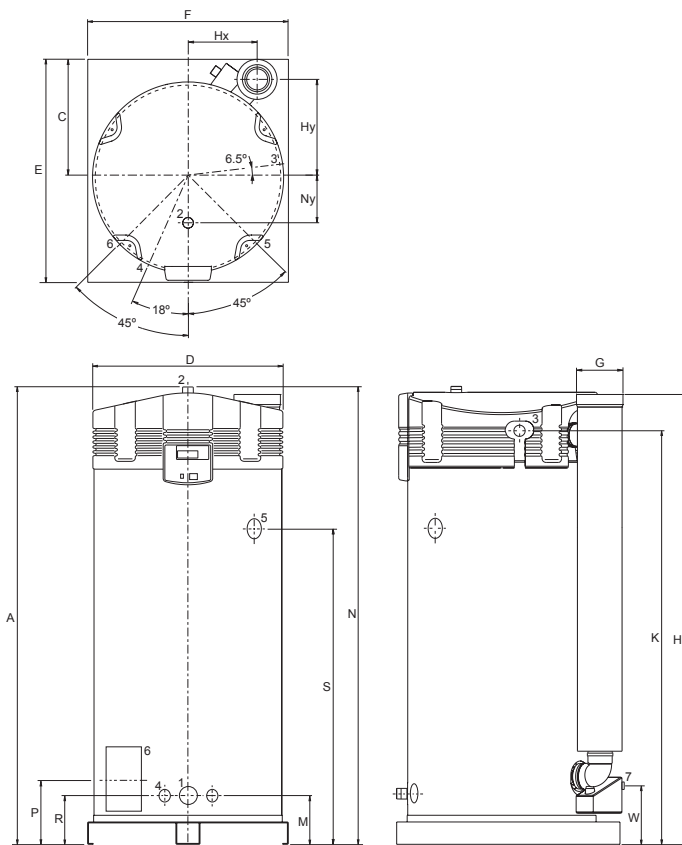

	BFC 28	BFC 30	BFC 50	BFC 60	BFC 80	BFC 100	BFC 120
A	1390	1925	1925	1925	2060	2060	2060
C	-	-	-	-	530	530	530
D	705	705	705	705	850	850	850
E	-	-	-	-	1000	1000	1000
F	-	-	-	-	900	900	900
G	100/150	100/150	100/150	100/150	130/200	130/200	130/200
H	1365	1890	1890	1890	1995	1995	1995
Hx	265	265	265	265	310	310	310
Hy	375	375	375	375	440	440	440
K	1285	1815	1815	1815	1855	1855	1855
M	170	160	160	160	225	225	225
N	1390	1925	1925	1925	2060	2060	2060
Ny	205	205	205	205	205	205	205
P	170	175	175	175	290	290	290
R	85	75	75	75	225	225	225
S	900	1410	1410	1410	1425	1425	1425
W	150	150	150	150	240	240	240

Dimensions in mm.

		BFC
1	Cold water (external)	R 11/2
2	Hot water (external)	R 11/2
3	Gas control (external)	R 3/4"
4	Tank drain valve (internal)	1" (28-60) 3/4" (80-120)
5	T&P valve (internal)	1" - 11.5 NPT
6	Cleaning and inspection opening	95x70
7	Condensation drainage (internal)	Ø 40

Dimensions in mm.

Installation diagrams

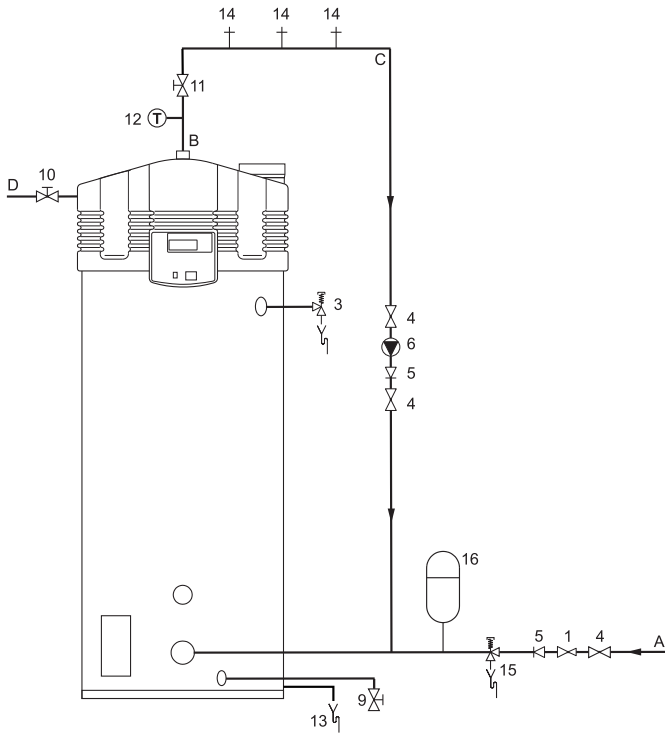

- | | |
|---------------------------|-----------------------|
| 1 Pressure reducing valve | A Cold water supply |
| 3 T&P valve | B Hot water outlet |
| 4 Stop valve | C Circulation pipe |
| 5 Non-return valve | D Gas supply |
| 6 Circulation pump | E Overflow pipe |
| 9 Drain valve | H Overflow protection |
| 10 Gas valve | |
| 11 Service valve | |
| 12 Temperature meter | |
| 13 Condense drain | |
| 14 Hot water tap | |
| 15 Expansion valve | |
| 16 Expansion vessel | |
| 17 Three way valve | |
| 18 Water cistern | |
| 19 Float valve | |

In the instruction manual you will find all the necessary information regarding connection, installation and maintenance of the product; including information on the electrical connections.

Information regarding the recycling or disposal of the product can also be found in the manual. This manual is delivered with the appliance and can also be found on our website: www.aosmithinternational.com.

Optional: Theta Dual Service

Theta dual service means using the available hot water from one of our water heaters for both domestic hot water (DHW) and heating. Dual service can be used in combination with a BFC Cyclone, SGE or BFC system. This is a perfect system for locations where a lot of domestic hot water and a little bit of heating is requested.

The intelligent control uses the available hot water very efficiently to meet the heating demand from one system without compromising comfort levels.

THETA MODULE FOR BFC		
Art. No.	kW CH capacity	ΔT CH system
TM 20 06	20	06
TM 20 10	20	10
TM 20 20	20	20
TM 30 06	30	06
TM 30 10	30	10
TM 30 20	30	20
TM 40 06	40	06
TM 40 10	40	10
TM 40 20	40	20

- Plate heat exchanger – single separation
(a double separated plate heat exchanger can be delivered upon request)
- Control with communication cable
- Primary DHW pump
- Temperature sensor with cable incl. clip
- Three-way mixing valve including cables
- Instruction manual

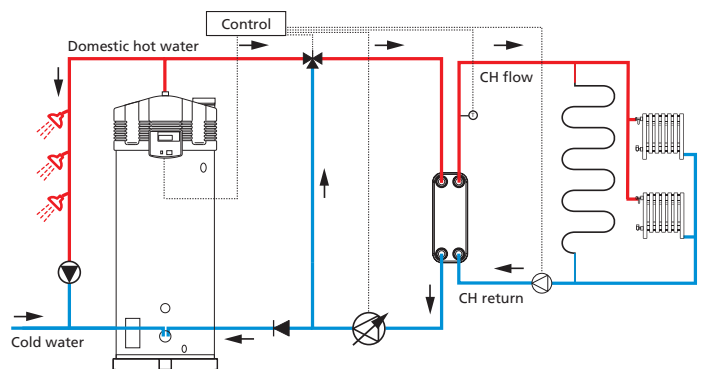

Further information is available on our website: www.aosmithinternational.com

Installation options

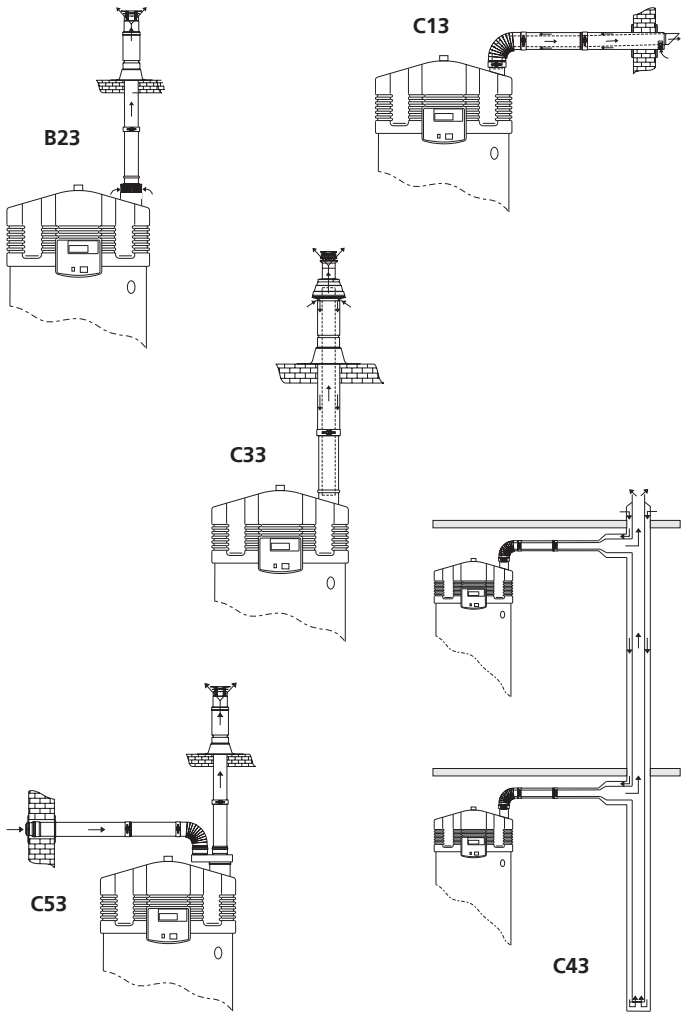

Further information on the specific flue discharge materials can be found in the installation manual.

A BFC water heater should be installed according category B23, C13, C33, C43 or C53*.

	BFC 28	BFC 30	BFC 50	BFC 60	BFC 80	BFC 100	BFC 120
Concentric							
Diameter (mm)	100/150			130/200			
Max. length (m)	40			15			
Max. 45/90° bends	7			4			
Parallel (standard diameter)							
Diameter (mm)	100			130			
Max. length (m)	55			65			
Lequivalent/bend 90° (m)	4.6			2.4			
Lequivalent/bend 45° (m)	1.2			1.4			
Parallel (larger diameter for more length)							
Diameter (mm)	130			150			
Max. length (m)	100			100			
Lequivalent/bend 90° (m)	2.4			2.6			
Lequivalent/bend 45° (m)	1.4			1.6			
* All BFC Cyclone water heaters are also approved for installations where the unit is supplied without venting materials (C63).							
Concentric flues							
It is not permitted to use more than the specified number of bends, even when the duct is shorter than the maximum length. A 45° bend is equivalent to a 90° bend.							
Parallel flues							
- The maximum permissible length should be reduced by the equivalent length of each bend. (Note: for a parallel installation this means that 3 changes in direction amount to 6 bends. 3 in the supply duct and 3 in the flue).							
- The maximum length also applies if a parallel installation has different supply and flue duct lengths (B23, C53).							
- Combined flues (C43) shall be fitted with a condensate drain.							
Note: Horizontal flue runs must be installed with a fall of at least 5 cm per metre.							

Minimum space requirements

BFC 28-60

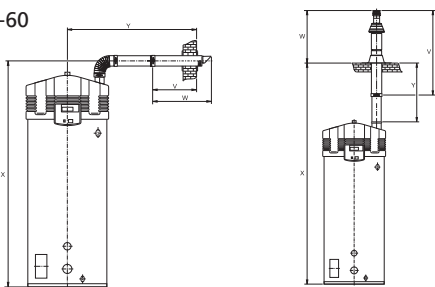

BFC 80-120

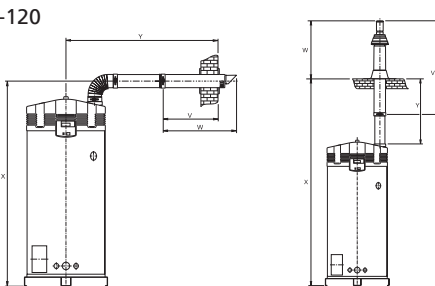

	BFC 28	BFC 30	BFC 50	BFC 60	BFC 80	BFC 100	BFC 120
	Ø100/150			Ø130/200			
Minimal space for wall duct (mm)							
V	550			640			
W	790			940			
X	1535	2075		2230			
X*	1985	2525		2680			
Y	1480			1620			
Y*	1030			1170			
Minimal space for roof duct (mm)							
V	1500			1730			
W	1035			1120			
X	2965	3325		3620			
X**	2015	2375		2670			
Y	1415			1560			
Y**	465			610			

* Distance without concentric pipe between bend and wall duct.
** Distance without concentric pipe between appliance and roof duct.

Data subject to change UK/0624/BFC/14
Terms and conditions apply, please refer to our website.